

Standard and CELDEK Evaporative Cooler Modules Installation, Operation, and Maintenance Manual



Standard Evaporative Cooler



CELDEK Evaporative Cooler

RECEIVING AND INSPECTION

Upon receiving unit, check for any interior and exterior damage, and if found, report it immediately to the carrier. Also check that all accessory items are accounted for and are damage free.

WARNING!!

Installation of this module should only be performed by a qualified professional who has read and understands these instructions and is familiar with proper safety precautions. Improper installation poses serious risk of injury due to electric shock, and other potential hazards. Read this manual thoroughly before installing or servicing this equipment. **ALWAYS** disconnect power prior to working on module.

Save these instructions: This document is the property of the owner of this equipment and is required for future maintenance. Leave this document with the owner when installation or service is complete.

TABLE OF CONTENTS

WARRANTY.....	4
INSTALLATION.....	5
Mechanical.....	5
Site Preparation.....	5
Assembly.....	5
Roof Mount Installation.....	7
Indoor (Inline) Installation.....	8
LPD Celdek Evaporative Cooler Adapter Plate Installation Instructions.....	9
Electrical.....	10
OPERATION.....	11
Freeze Protection.....	11
Timer Settings.....	11
Nozzle Replacement.....	14
Start Up.....	16
Special Tools Required.....	16
Start Up Procedure.....	16
Component Description/Detail.....	17
Troubleshooting.....	18
Troubleshooting Chart.....	18
MAINTENANCE.....	19
General Maintenance.....	19
Every 3 months.....	19
Yearly.....	19
Start-Up and Maintenance Documentation.....	20

WARRANTY

This equipment is warranted to be free from defects in materials and workmanship, under normal use and service, for a period of 24 months from date of shipment. This warranty shall not apply if:

1. The equipment is not installed by a qualified installer per the MANUFACTURER'S installation instructions shipped with the product,
2. The equipment is not installed in accordance with federal, state and local codes and regulations,
3. The equipment is misused or neglected,
4. The equipment is not operated within its published capacity,
5. The invoice is not paid within the terms of the sales agreement.

The MANUFACTURER shall not be liable for incidental and consequential losses and damages potentially attributable to malfunctioning equipment. Should any part of the equipment prove to be defective in material or workmanship within the 24 month warranty period, upon examination by the MANUFACTURER, such part will be repaired or replaced by MANUFACTURER at no charge. The BUYER shall pay all labor costs incurred in connection with such repair or replacement. Equipment shall not be returned without MANUFACTURER'S prior authorization and all returned equipment shall be shipped by the BUYER, freight prepaid to a destination determined by the MANUFACTURER.

INSTALLATION

It is imperative that this unit is installed and operated with the designed airflow and electrical supply in accordance with this manual. If there are any questions about any items, please call the service department at **1-866-784-6900** for warranty and technical support issues.

Mechanical

WARNING: DO NOT RAISE VENTILATOR BY THE INTAKE HOOD, FILTER TRACKS, OR PIPING – USE LIFTING LUGS PROVIDED OR A SLING

Site Preparation

1. Provide clearance around installation site to safely rig and lift equipment into its final position. Supports must adequately support equipment. Refer to manufacturer's estimated weights.
2. Consider general service and installation space when locating unit. Use the clearance chart for clearance specification on control side.
3. Do not allow air intake to face prevailing winds. Support unit above ground or at roof level high enough to prevent precipitation from being drawn into its inlet. The inlet must also be located at least 10 feet away from any exhaust vents.

Table 1 – Service Clearance

Size	Clearance (inch)
1	30"
2	38"
3	42"
4	49"
5	60"
6	78"

Assembly

There are several items shipped loose with the evaporative coolers. These items include the drain trap components, sheet metal screws, nuts and bolts, screen intakes (for outdoor installations), equipment legs (for outdoor installations), and hanging cradles (option for indoor applications). Upon unit arrival, follow the following procedure to assemble the evaporative cooler:

1. Attach the evaporative cooler to the ventilator or duct using the sheet metal screws and nuts and bolts included. Ensure that there is a liquid tight seal formed between the evaporative cooler and the ventilator.
2. Screw the flanges of the intake screen to the unit with the supplied sheet metal screws. (Outdoor installations only).
3. Fans designed for outdoor installation are provided with adjustable equipment legs. The adjustable legs should be used to support and level the front end of the evaporative cooler.

Figure 1 - Assembly

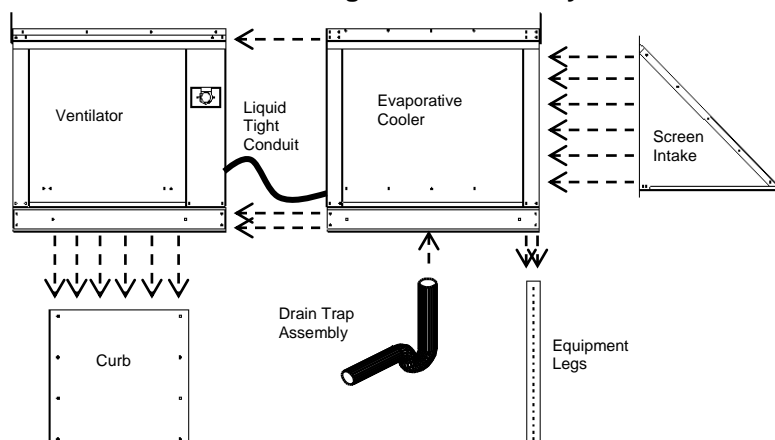

Plumbing Connections

There are two field plumbing connections required for proper evaporative cooler operation. It is recommended that all plumbing connections be sealed with Teflon tape or pipe dope. Use care not to contaminate the interior surfaces of the water lines when plumbing the unit, as small particulate can clog the orifices of the spray nozzles.

1. The P-Trap drain should be attached underneath the cooler (hardware is provided and drain is installed). The trap is important for two reasons. First, it can be piped to drain in the most convenient area. Second, it keeps air from being drawn through the drain hole in the bottom of the pan, impeding drainage.
2. Pipe the main water supply line to quick seal on the bottom of the unit. Install a strainer with sediment trap on the water inlet. Minimum pressure for optimal performance is 30 PSI. Maximum pressure should not exceed 50 PSI. **It is highly recommended that a water-softener be installed up-stream of the unit to extend cooling media life and prevent scale build-up in unit.**

Figure 2 – P-Trap

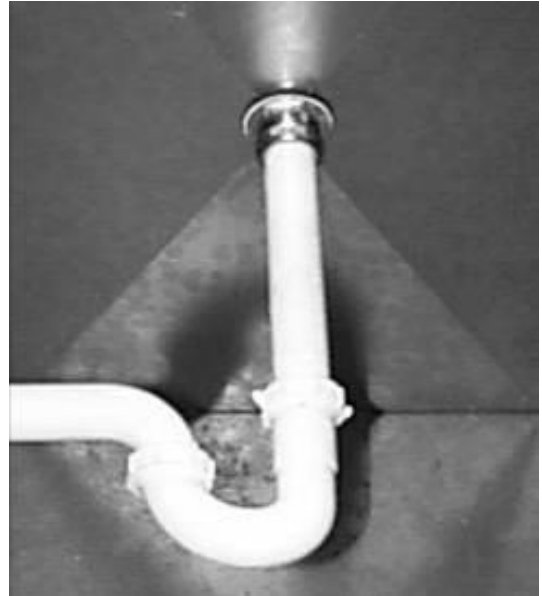

Roof Mount Installation

Figure 3

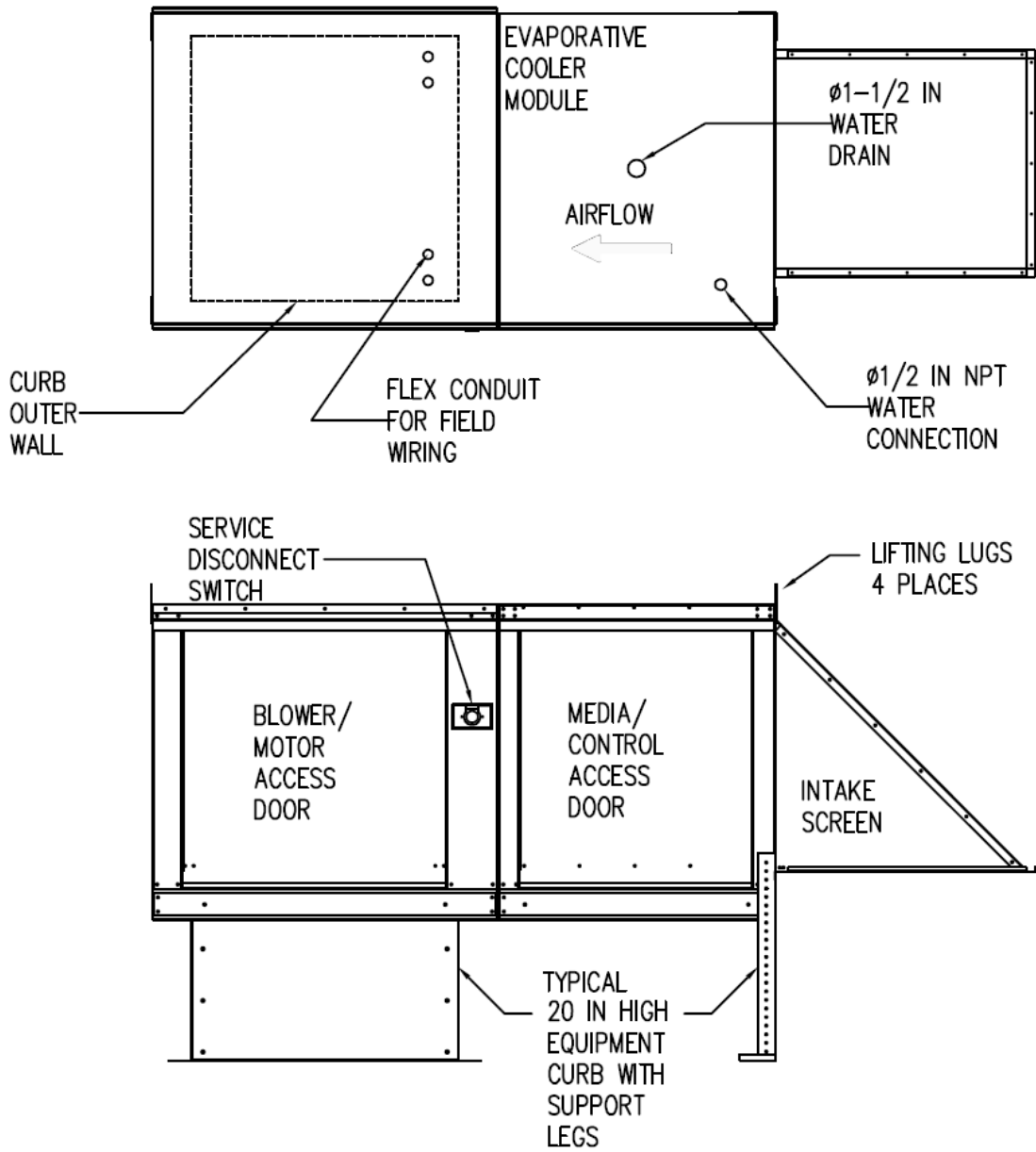

Indoor (Inline) Installation

Figure 4

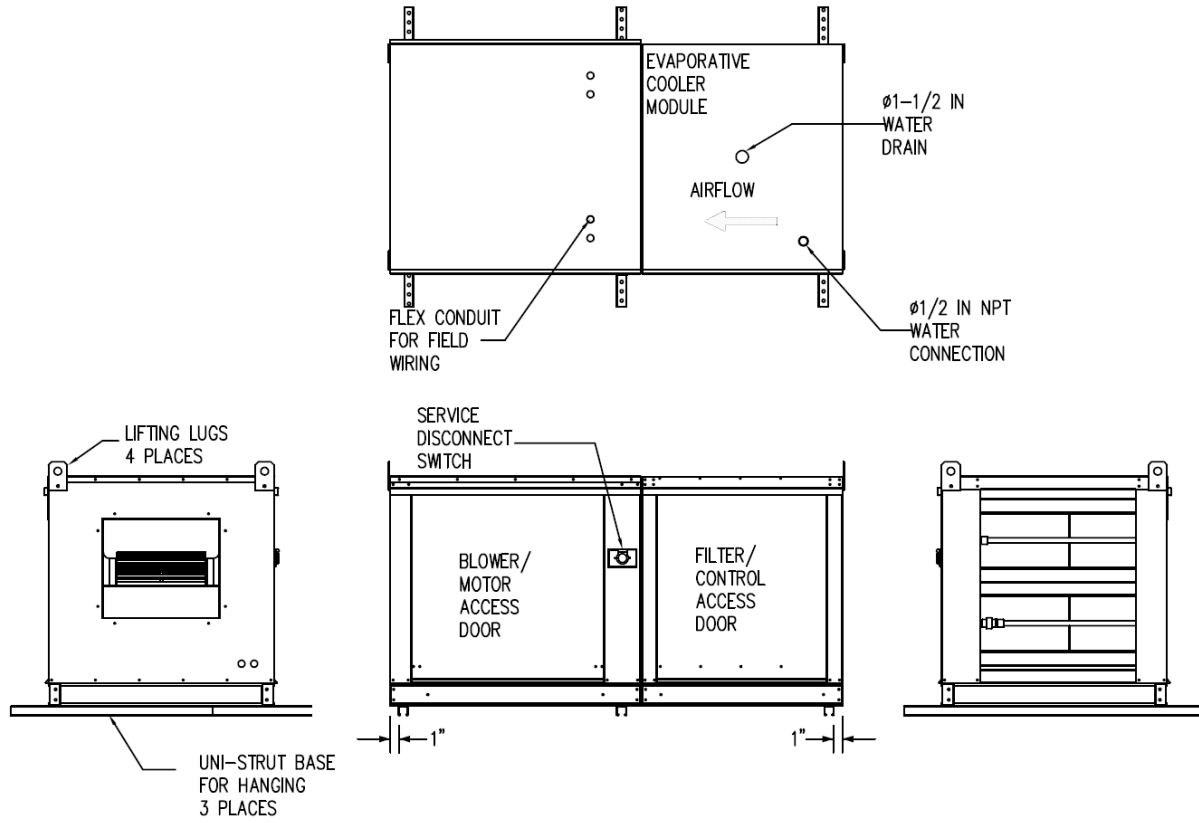

LPD Celdek Evaporative Cooler Adapter Plate Installation Instructions

Figure 5

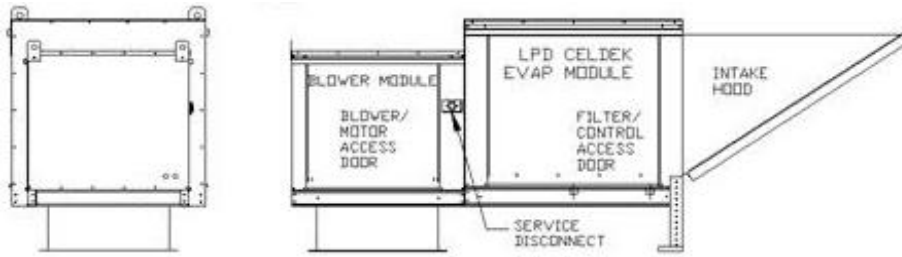

1. Apply the standard 1/4" x 1" gray gasketing around the perimeter of the smaller-size blower module. This is the same as you would normally do before attaching a module of similar size.
2. Align the smaller Make-Up Air (MUA) unit and the larger cooling module next to each other so that the bolt holes line-up. Use the appropriate hole locations to bolt the two units together.
3. Use self-tapping sheet metal screws to drill through and secure the perimeter of the smaller blower module to the adapter plate.

Figure 6

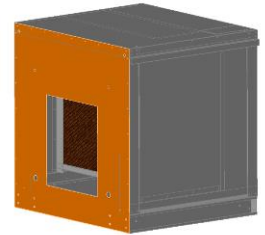

NOTE: There are no pre-punched holes for this purpose. A screw should be placed approximately every 4-5" in order to fully compress the gasket between the two modules.

Figure 7

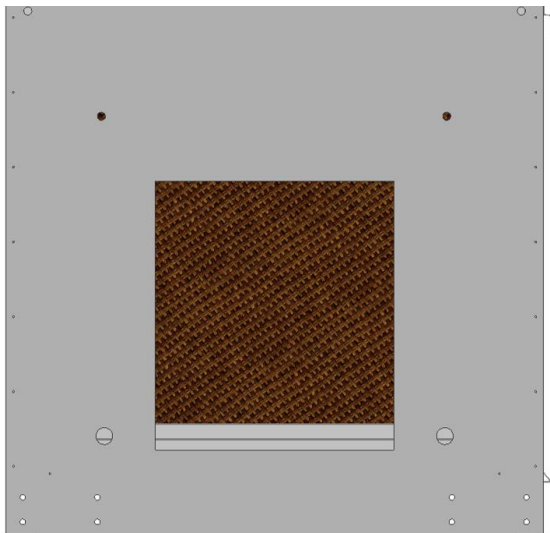
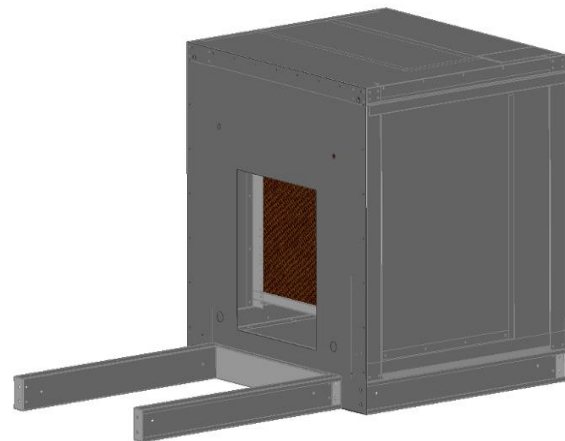

Figure 8



Electrical

WARNING!!

Disconnect power before installing or servicing module. High voltage electrical input is needed for this equipment. This work should be performed by a qualified electrician.

Before connecting power to the module, read and understand the entire section of this document. As-built wiring diagrams are furnished with each module by the factory, and are attached either to the door of the unit or provided with a paperwork packet.

Electrical wiring and connections should be done in accordance with local ordinances and the National Electric Code, ANSI/NFPA70. Be sure the voltage and phase of the power supply and the wire amperage capacity is in accordance with the unit nameplate. For additional safety information refer to AMCA publication 410-96, *Recommended Safety Practices for Users and Installers of Industrial and Commercial Fans*.

Table 2 - Copper Wire Ampacity

Wire Size AWG	Maximum Amps
14	15
12	20
10	30
8	50
6	65
4	85

1. Always **disconnect power** before working on or near this equipment. Lock and tag the disconnect switch or breaker to prevent accidental power up.
2. An electrical drop containing the line voltage power wiring is shipped with every evaporative cooler. The electrical drop should be brought through one of the conduit openings located in the front of the module and connected to an appropriate power source.
3. Make certain that the power source is compatible with the requirements of your equipment. The evaporative cooler wiring schematic identifies the **proper phase and voltage** of the equipment.
4. Before connecting evaporative cooler to power source, verify power line wiring is de-energized.
5. Secure the power cable to prevent contact with sharp objects.
6. Do not kink power cable and never allow the cable to come in contact with oil, grease, hot surfaces or chemicals.
7. Before powering up the evaporative cooler make sure that the interior of the unit is free of loose debris or shipping materials.
8. If any of the original wire supplied with the cooler must be replaced, it must be replaced with type THHN wire or equivalent.

OPERATION

Prior to starting up or operating the evaporative cooler, check all fasteners for tightness. Ensure that the cooling media is installed properly and that the interior of the cooler is free of loose debris.

The evaporative cooler is equipped with a 2 setting timer control. The UPPER 2 dials are used to denote the length of time the manifold sprays water while the LOWER 2 dials control the amount of time between spray periods. Both of these settings are factory set and should not have to be adjusted during initial installation of the unit. It is important to understand that the spray timing pattern is cyclic in nature with the manifold discharging water on and off continuously based on the timers dial settings. Both the standard and Calder evaporative coolers are shipped from the factory with specific nozzles with varying characteristics regarding flow rates and anti-drip protection. **It is imperative that the correct nozzle is used in the correct location and type of cooling module to ensure quality performance and leakage prevention. Information regarding the nozzles and timer control should be read and understood before commencing unit start-up procedures.**

Freeze Protection

On units shipped with the optional freeze protection drain kit, additional field wiring and piping is required. A 3-way water solenoid is provided; containing a normally open and a normally closed valve, and should be installed below the roof line and be wired and piped as shown to the right. **Additional details on how to install this 3 way solenoid valve are included in the [Component Detail](#) section (page 17) of this manual.** A 2-stage thermostat is also provided in the evaporative cooler when the freeze protection option is ordered. The evaporative cooler will automatically drain when the ambient temperature falls below the internal two stage thermostat set-point.

Figure 9 – Optional Freeze Protection Kit

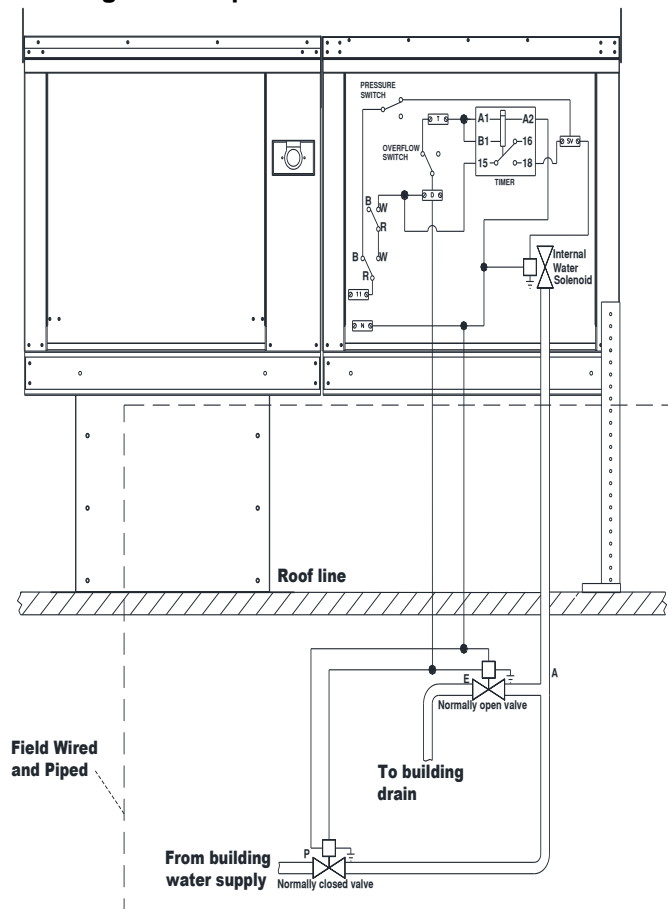

Timer Settings

Figure 10

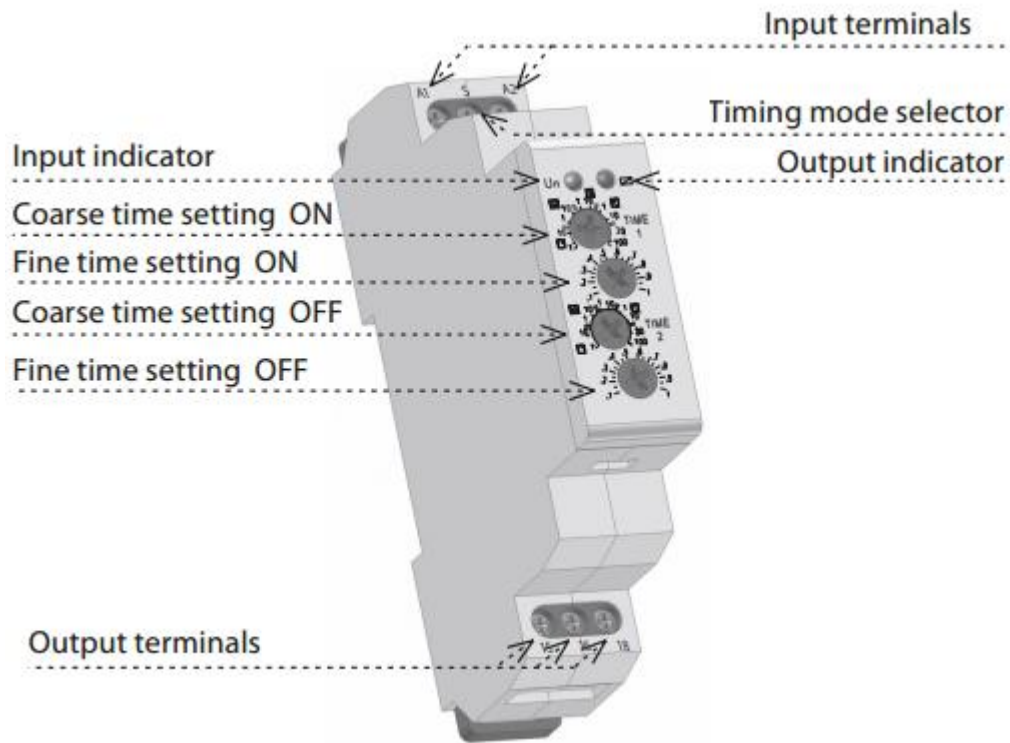

Both the upper and lower timer settings are adjusted using the same procedure. The UPPER section controls the length of time the manifold sprays water, while the LOWER section controls the amount of time between spray periods. **Both of these parameters are set in the factory and should not have to be adjusted during initial start-up. If adjustments to airflow are made, the timer settings will need to be adjusted to sustain proper performance.**

The procedure for setting the Timer control is as follows:

- 1) Set the two coarse time setting dials to "1 MIN". THESE ARE ALWAYS SET TO "1 MIN" FOR ALL UNITS REGARDLESS OF SIZE AND TYPE.
- 2) Set the "fine time setting off" dial located on the LOWER portion of the timer. THIS IS ALWAYS SET TO "1.0" FOR ALL UNITS REGARDLESS OF SIZE AND TYPE.
- 3) Using the table at the bottom of this page, calculate the time parameter of how many seconds the manifold will spray based on the given CFM of the unit.
- 4) Set the "fine time setting on" dial located on the UPPER portion of the timer. For each time parameter, the values of both the fine adjustment and coarse adjustment dials are multiplied by one another to denote the total time of the parameter. The fine time setting dials are percentages of the course time settings. For example, if the course dial is set to 1 minute, and the fine dial is set to 0.5, the selected time period would result in 30 (1 minute * 0.5 = 30 Sec) seconds. Check to ensure that the parameter for "spray time on" matches the amount of time calculated in step 3.

Table 3

Unit Size	*Time "Spray - On" (LOWER timer setting in SEC.)
1	$CFM*(15/3000) + 6.5$
2	$CFM*(15/4000) + 1.5$
3	$CFM*(15/4500) - 1$
4	$CFM*(15/9000) - 1$
5	$CFM*(15/12,000) - 3.5$
6	$CFM*(15/15,000) - 5$

***NOTE: THE VALUE GENERATED FROM THE EQUATIONS IN THE TABLE IS FOR SECONDS THAT THE MANIFOLD IS TO SPRAY WATER. IT IS NOT THE FINE DIAL SETTING. STEP "4" MUST BE CARRIED OUT IN ORDER TO PROPERLY SET THE FINE TIME SETTING ON DIAL.**

Nozzle Replacement

The standard and Celdek style evaporative units each have each been designed with their own specific water manifolds and nozzles in order to deliver maximum spray coverage and correct quantity of water to the cooling media. It is imperative that in the event of a nozzle change-out, the nozzles match what is specified in this section of the manual. Nozzle threads must be wrapped in Teflon tape to prevent leakage.

Figure 11 - CELDEK Evaporative Cooler Water Manifold

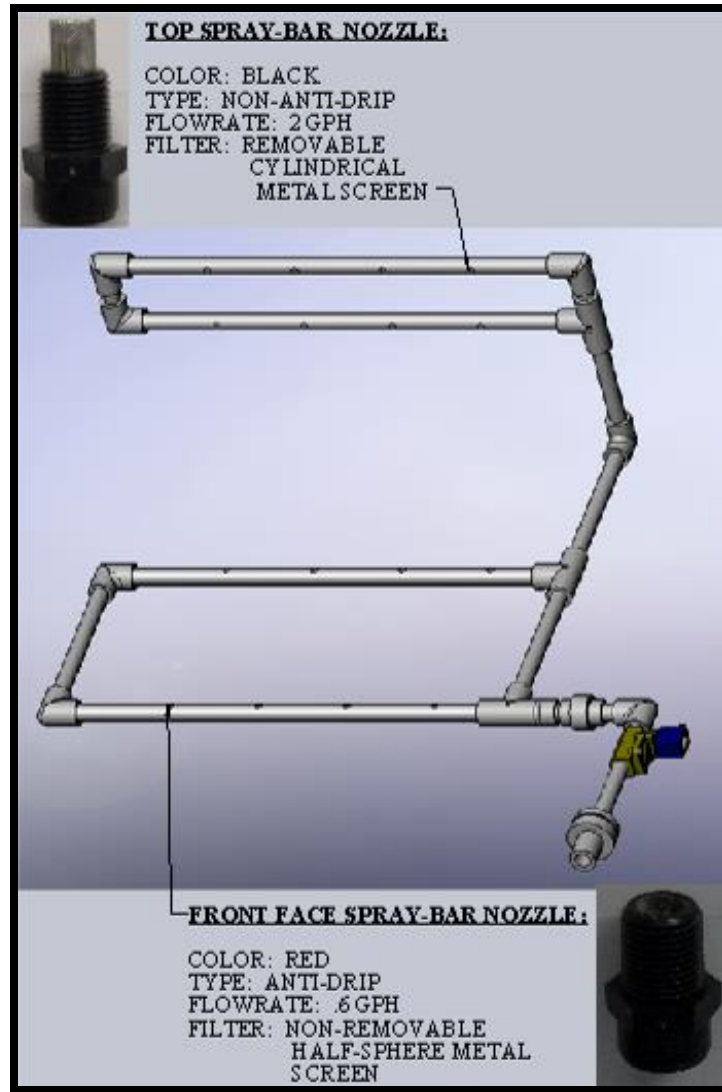
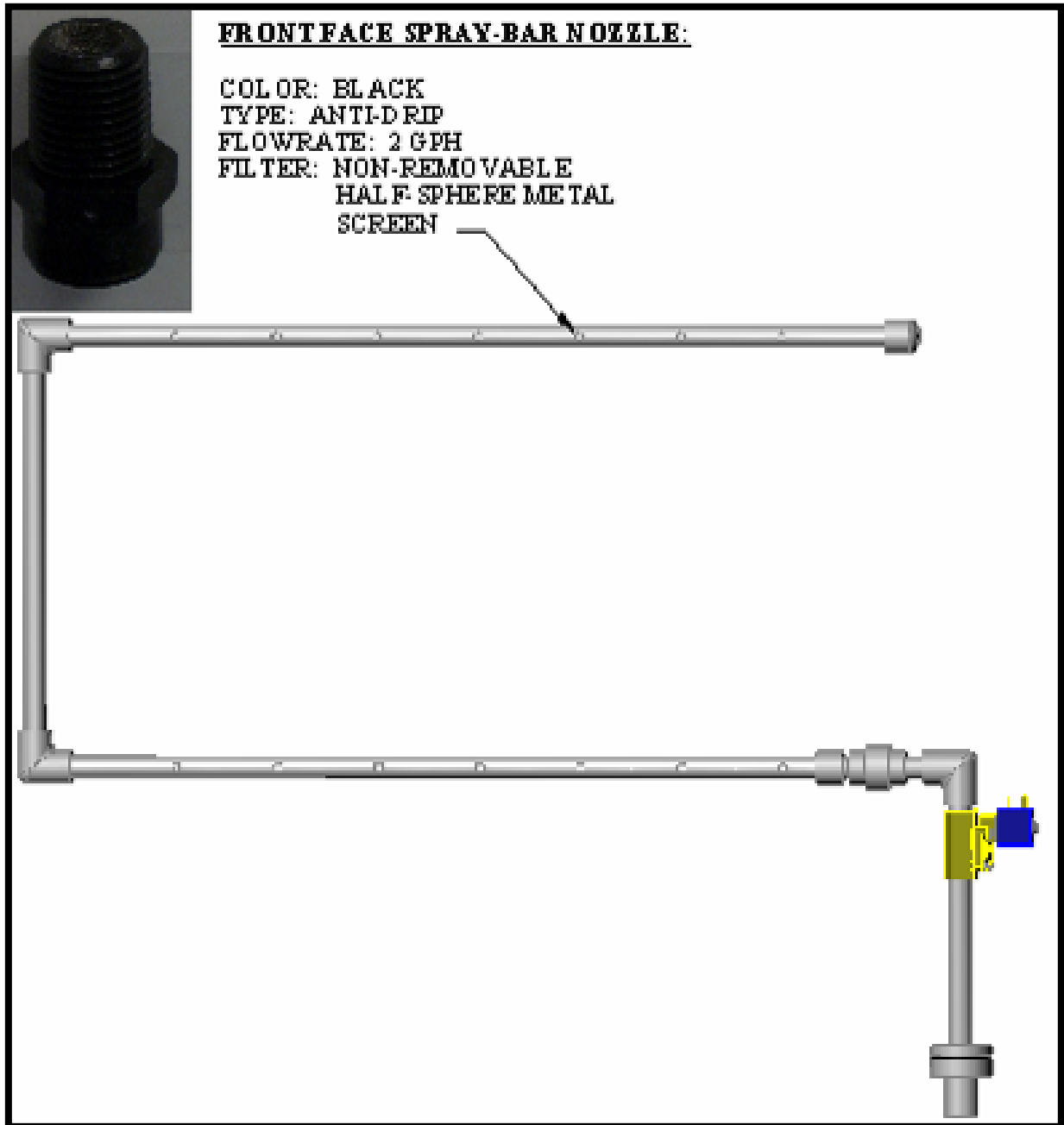

Figure 12 - Standard Evaporative Cooler Water Manifold



Start Up

Special Tools Required

- AC Voltage Meter
- Amperage Meter
- Standard Hand Tools

Start Up Procedure

1. Remove the access door and check all electrical connections for tightness and continuity.
2. Inspect the air-stream for obstructions and install cooling media if missing.
3. Compare the supplied **voltage** with the unit's nameplate voltage. If this does not match, correct the problem.
4. Set the internal thermostat to a set-point cooler than the entering air temperature for start-up purposes. The cooling circuit will be energized when the entering air temperature is hotter than the thermostat set-point.
5. Check the timers dial settings. Ensure that the timer's settings match what is specified in the above section of this manual under [Timer Settings](#) (page 11).
6. Install the access door and apply power to the unit. If the entering air temperature is hotter than the thermostat set-point, the cooling circuit will be energized and water will begin spraying from the nozzles. If no water sprays, the unit is either not powered, has no water pressure or the entering air temperature is cooler than the thermostat set-point.
7. **Observe the spray timing sequence.** Make sure that the sequence observed matches what is specified based on CFM to optimize evaporative cooler performance. The unit should spray enough to keep the media wet with minimal run-off and light drainage. It takes roughly 20 minutes for the cooling media to become fully saturated and come up to steady state operating conditions. If there is no water in the drain pan and no run-off of the media, the "spray-time on" parameter should be increased to lengthen the time water is sprayed. If there is excessive runoff and quantities of drainage, the "spray-time on" parameter should be decreased to shorten the time water is sprayed. Set the thermostat back to the desired cooling temperature (typically about 85°F). Remember, the cooling circuit will only be energized when the entering air temperature is higher than the set-point.

Component Description/Detail

The following table lists controls used in the evaporative cooler and their function:

Table 4 – Electrical Cabinet Components

Component Number	Component	Description of Operation
1	Timer	Controls spray timing sequence. Runs continuously from spray time on and spray time off.
2	Thermostat	Energizes cooling circuit when entering air temperature exceeds set-point
3	Solenoid Valve	Normally closed valve. Depending on model, either controlled by a timer or energized when liquid level controller senses “dry” condition.
4	Overflow switch	Normally closed switch. Detects clogged drain to prevent overflow.
5*	Pressure Switch	Normally closed switch. Prevents unit from continually spraying if 3way solenoid valve used for freeze protection is not installed in field.
6*	3 Way solenoid Valve	Installed under roof-line. Allows gravity-fed drainage in sub-freezing ambient conditions.

Figure 13 - Electrical Cabinet Detail

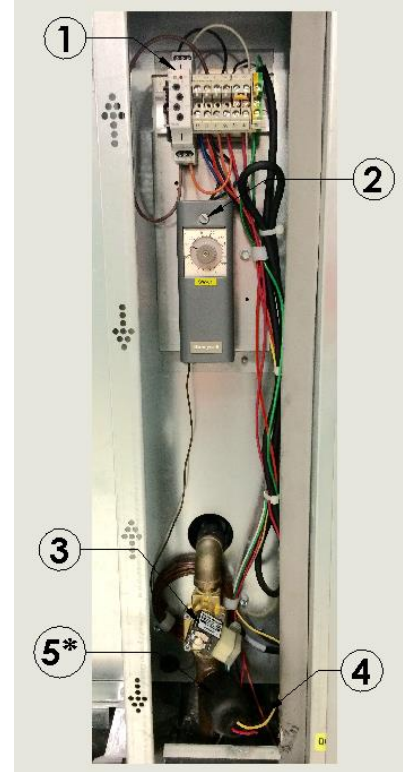

Units with Freeze Protection Option:

***NOTE:** Only installed on units with Freeze protection.

NOTICE: IT IS THE RESPONSIBILITY OF THE INSTALLER TO ENSURE 3-WAY SOLENOID VALVE IS INSTALLED UNDER THE ROOF-LINE ON THE WATER-LINE UPSTREAM OF THE UNIT. THE MANUFACTURER IS NOT RESPONSIBLE FOR ANY DAMAGE RESULTING FROM THE FAILURE OF INSTALLING THIS 3-WAY SOLENOID VALVE PRIOR TO START-UP.

Figure 14 - 3-way Solenoid Valve Detail (Field Installed under Roofline)

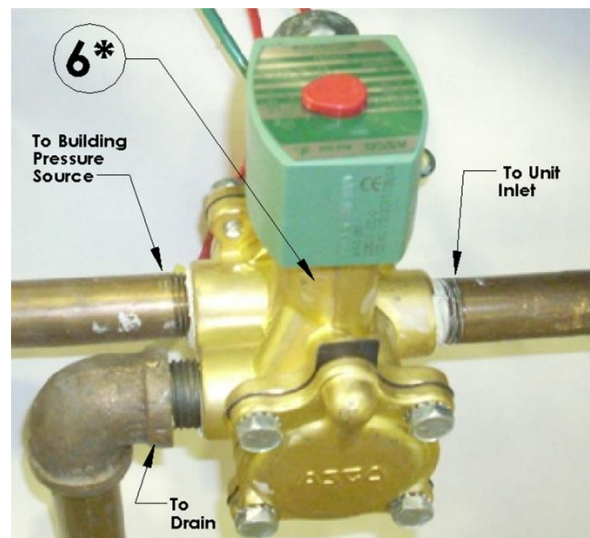

Troubleshooting

The following table lists causes and corrective actions for possible problems with evaporative coolers. Review this list prior to consulting manufacturer.

Troubleshooting Chart

Problem	Potential Cause	Corrective Action
Insufficient Cooling	Media not wet	Check for even spray pattern from all nozzles
	Clogged nozzles	Clean or replace nozzles
	Timer Settings improperly set	Ensure that the timers dial setting settings correspond to those specified in the reference table of this manual based on face velocity.
	Internal thermostat set to high	Set thermostat to lower setting. Cooling circuit will be energized when the outside air temperature is higher than thermostat set-point
	No water pressure	Turn main building water valve on
	Clogged drain causing pan overflow switch to activate	Clear any debris from drain and ensure bottom pan drains properly. Ensure that the overflow switch float mechanism is able to travel up and down freely
	Excessive ambient humidity	Wrong application for evaporative cooling
	Cooling media dirty	Clean or replace cooling media
Insufficient Airflow	Cooling media clogged	Clean or replace cooling media
Excessive Airflow	Cooling media missing	Install cooling media

MAINTENANCE

To guarantee trouble free operation of this evaporative cooler, the manufacturer suggests following these guidelines. Most problems associated with unit failures are directly related to poor service and maintenance.

Please record any maintenance or service performed on this equipment in the documentation section located at the end of this manual.

WARNING: DO NOT ATTEMPT MAINTENANCE ON THE EVAPORATIVE COOLER UNTIL THE ELECTRICAL SUPPLY HAS BEEN COMPLETELY DISCONNECTED

General Maintenance

1. Inlet and approaches to evaporative cooler should be kept clean and free from any obstruction.
2. All fasteners should be checked for tightness each time maintenance checks are performed prior to restarting unit.
3. Evaporative coolers require little attention when moving clean air. Occasionally oil and dust may accumulate on cooling media causing low airflow or reduced cooling. Cooling media should be inspected and cleaned every 3 months and replaced every cooling season.

Every 3 months

1. Cooling media needs to be cleaned and/or replaced (if damaged) quarterly, and more often in severe conditions. Cooling media can be washed with a standard water hose. When re-installing cooling media, be sure to install with the **airflow in the correct direction**. The standard v-bank style evaporative cooler media should be installed with the metal mesh side of the pad on the leaving air side of the media. The CELDEK media should be installed with the 15° holes along the air stream path as indicated in the CELDEK installation illustration.
2. Check all fasteners, sensors and electrical connections for proper tightness and continuity.
3. Check all nozzles for proper and evenly distributed water flow. If nozzles are clogged, clean or replace.

Figure 15 - CELDEK Installation

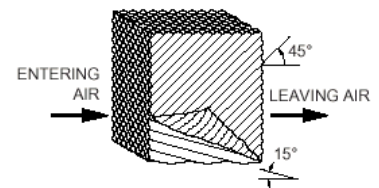

Yearly

1. Replace cooling media prior to cooling season. Cooling media should be replaced yearly to guarantee proper cooling performance. The following table illustrates proper media quantities and sizes.
2. Check the piping manifold and evaporative cooler housing for water tightness. Replace or repair any leaking or damaged components.
3. Every cold season requires that the evaporative cooler water piping system be drained to prevent freezing and cracking of the water piping. The main water supply should also be turned off for the cold season. Standard mesh filters may be used in standard v-bank coolers in cold seasons.

Table 5 - Cooling Media Size and Quantity

Intake	Quantity	Size
Size 1 V-Bank/Evap	3	20" x 25"
Size 2 V-Bank/Evap	8	16" x 20"
Size 3 V-Bank/Evap	8	20" x 25"
Size 4 V-Bank/Evap	15	16" x 20"
Size 5 V-Bank/Evap	12	20" x 25"
Size 6 V-Bank/Evap	18	20" x 25"
Size 1 CELDEK	1	24" x 20"
Size 2 CELDEK	1	32" x 25"
Size 3 CELDEK	1	36" x 30"
Size 4 CELDEK	1	43" x 38"
Size 5 CELDEK	1	54" x 45"
Size 6 CELDEK	1	72" x 45"

Start-Up and Maintenance Documentation

START-UP AND MEASUREMENTS SHOULD BE PERFORMED AFTER THE SYSTEM HAS BEEN AIR BALANCED (Warranty will be void without completion of this form)

Job Information

Job Name	
Address	
City	
State	
Zip	
Phone Number	
Fax Number	
Contact	
Purchase Date	

Service Company	
Address	
City	
State	
Zip	
Phone Number	
Fax Number	
Contact	
Start-Up Date	

Evaporative Cooler Information

Refer to the start-up procedure in this manual to complete this section.

Name Plate and Unit Information	
Model Number	
Serial Number	
Volts	
Hertz	
Phase	

Field Measured Information		
Voltage		
Thermostat Set-Point	°F	
Time spray on (Sec)		
Time spray off (Sec)		
Airflow Direction	Correct	
	Incorrect	

Maintenance Record

Date	Service Performed

**Factory Service Department
Phone: 1-866-784-6900
Fax: 1-919-554-9374**



TERMS AND CONDITIONS OF SALE FOR TEMPERED FANS

THESE TERMS AND CONDITIONS OF SALE (“TERMS”) CONTAIN VERY IMPORTANT INFORMATION REGARDING YOUR PURCHASE, AS WELL AS CONDITIONS, LIMITATIONS, AND EXCLUSIONS THAT APPLY TO YOU AND YOUR PURCHASE. PLEASE READ THEM CAREFULLY. YOUR PURCHASE IS EXPRESSLY LIMITED TO AND MADE CONDITIONAL UPON THE EXCLUSIVITY OF THESE TERMS. ANY PROPOSAL FOR DIFFERENT TERMS OR ANY ATTEMPT TO VARY, IN ANY DEGREE, ANY OF THESE TERMS IS EXPRESSLY REJECTED.

- 1. Acceptance.** These Terms govern any purchase made from North American Kitchen Solutions Incorporated (“**NAKS**”). These Terms, the Manual in which they are contained, installation and maintenance instructions, the applicable invoice, and any documents incorporated or referred to herein or therein, including any future paper or electronic releases issued by NAKS, constitute the “Order.” The Order is the entire contract between you, the buyer, and NAKS, the seller, for products purchased from NAKS. These Terms apply to the Order unless expressly modified or waived in writing by an officer of NAKS. An Order may only be cancelled by you upon payment of reasonable cancellation charges for expenses incurred or commitments made by NAKS. Captions in these Terms are for convenience only.
- 2. Pricing.** The price for NAKS’ goods, material, equipment, or items (“**Products**”) is complete, and no deductions, credits, or offsets may be made without NAKS’s express written consent. Prices are subject to change and surcharges in the event of cost increases in materials and transportation. All complete component accessory material manufactured by others and furnished with Products such as motors, drives, vibration equipment, controls, or other completely assembled component structures, are subject to adjustment to the price at time of shipment regardless of the date of original order entry.
- 3. Sales and Similar Taxes.** NAKS’ prices do not include sales, use, excise, or similar taxes. Present or future sales, use, excise, or other similar tax applicable to the sale of Products shall be paid you, unless an acceptable tax exemption certificate is provided to NAKS.
- 4. Payment.** NAKS reserves the right to require full or partial payment in advance of any order if, in NAKS judgment, the financial condition of buyer does not justify continuation of manufacture or shipment. NAKS may require full or partial payment in advance. Pro-rata payments are due as shipments are made. Each shipment or delivery shall constitute a separate sale, and the default of any shipment or delivery shall constitute a separate sale, and the default of any shipment or delivery shall not vitiate the contract as to other shipments or deliveries.
- 5. Return Policy – ALL SALES ARE FINAL.** Because we custom manufacture equipment to each customer’s specifications, **ALL SALES ARE FINAL.** We may accept the return of non-custom goods at our discretion, but a restocking fee of 30% will apply and all shipping costs are the responsibility of the purchaser or end user. No merchandise may be returned without a Return Goods Authorization (RGA). Items returned for warranty replacement or exchange will not be eligible for credit if not received within 14 days of the issuance of a Return Goods Authorization.
- 6. Delivery.** Shipping and delivery dates are estimates only. No delay in delivery will subject NAKS to any costs, damages or fees for late delivery. Delivery of Products is made F.O.B. point of shipment, unless otherwise stated. NAKS shall not be liable for delay due to causes beyond its reasonable control (i.e., force majeure events). In the event of such a delay, the date of delivery shall be extended for a period equal to the time lost by reason of the delay.
- 7. Changes.** NAKS may make changes, including improvements and additions, in the technical requirements, specifications, designs, materials, packaging, and place of delivery, method of transportation, quantities, or delivery schedules of the Products by notifying you.
- 8. Safety.** The Products may be designed to serve multiple applications. NAKS offers a range of safety equipment, including guards and other devices, as may be required to meet customer specifications. Without exception, NAKS recommends that all orders include applicable safety devices. Use of Products ordered without applicable safety devices is your sole responsibility. You warrant that you have determined and acquired any and all safety devices required for the Products. Weather covers and guards for motor and V-belt drives, couplings, shafts and bearings, along with inlet and outlet screens, are optional accessories noted in the price list.

9. **Title.** Title and right of possession of Products remains with NAKS until all payments (including deferred payments whether evidenced by notes or otherwise) shall have been received to the satisfaction of NAKS and you agree to do all acts necessary to perfect and maintain such title and right in NAKS and not to subject any Products to any liens or encumbrances until such payment is made in full.

10. **Governing Law.** This Order shall be governed by and construed according to the laws of the State of Ohio (excluding the conflict of law provisions thereof). At NAKS' discretion, any action relating directly or indirectly to the Order shall be brought exclusively in the Common Pleas Court of Cuyahoga County, Ohio or the United States District Court for the Northern District of Ohio, Eastern Division, and you irrevocably waive any objection to the jurisdiction of, or venue in, either of these courts and agree that the acceptance of the Order constitutes doing business in the State of Ohio.

11. **Arbitration.** At NAKS' discretion, any dispute arising under or in connection with any Order may be submitted to binding arbitration administered by the American Arbitration Association under its Commercial Arbitration Rules, and judgment on the award rendered by the arbitrator may be entered in any court having jurisdiction thereof. The dispute shall be resolved by one neutral arbitrator who shall have no affiliation with either you as the buyer or with NAKS and shall be selected by the American Arbitration Association office, and held in, Cleveland, Ohio.

WARNING. NAKS' Products are designed and manufactured to provide reliable performance but they are not guaranteed to be 100% free of defects. Even reliable products will experience occasional failures and this possibility should be recognized by the buyer and all end users. If Products are used in life support ventilation systems where failure could result in loss or injury, the buyer and all end users should provide adequate back-up ventilation, supplementary natural ventilation or failure alarm system, or acknowledge willingness to accept the risk of such loss or injury. **DO NOT USE IN HAZARDOUS ENVIRONMENTS** where a fan's electrical system could provide ignition to combustible or flammable materials unless unit is specifically built for hazardous environments. Comply with all local and national safety codes including the National Electrical Code (NEC) and National Fire Protection Act (NFPA).

CAUTION. Guards must be installed when fan is within reach of personnel or within eight (8) feet (2.5 m) of working level or when deemed advisable for safety.

DISCLAIMER. NAKS has made a diligent effort to illustrate and describe the Products accurately in all materials; however, such illustrations and descriptions are for the sole purpose of identification and do not express or imply any warranty.

LIMITED WARRANTY

WARRANTY AND DISCLAIMER. This limited warranty extends to the original purchaser only with proof of purchase. NAKS warrants that Products shall be free from original defects in workmanship and materials for two years from date of shipment provided the Products have been properly handled, stored, installed, serviced, maintained, and operated. This warranty shall not apply to Products which a) have been altered or repaired without NAKS' written express authorization, b) have been altered or repaired in any way so as, in NAKS' judgment, to affect performance or reliability, c) have been improperly installed, d) have been subjected to misuse, negligence, or accident, or e) have not been installed and operated in accordance with federal, state and local codes and regulations. Wear items, such as V-Belts, filters, etc. are not included as covered parts under this Warranty. Reimbursement for labor for removing and/or re-installing replacement parts is included in this Warranty for a period of 30 days from field start-up or 90 days from Shipment, whichever comes first. NAKS, Inc. is responsible in its sole discretion for determining the amount of labor reimbursement allowed based upon the circumstances of each installation. Labor cost reimbursement must be approved by NAKS in writing prior to the work being performed. You assume all risks and liability for results of use of all Products.

LIMITATION OF REMEDY AND DAMAGES. All claims under this warranty must be made in writing and delivered by U.S. Mail to:

North American Kitchen Solutions
172 Reaser Court
Elyria, OH 44035
Attn: WARRANTY CLAIMS DEPARTMENT

All Product claims must be made within 15 days after discovery of the defect and prior to the expiration of two years from the date of shipment. Claims made beyond that period are barred. Within 30 days after receipt of a timely claim, NAKS shall have the option either to inspect the Product at its location or request its return to NAKS at your expense. NAKS shall replace, or at its option repair, free of charge, any Product it determines to be defective, and it shall ship the repaired or

replacement product to you F.O.B. point of shipment; provided, however, if in NAKS' judgment circumstances are such to prohibit repair or replacement to remedy the warranted defects, your sole and exclusive remedy shall be a refund of any part of the invoice price, paid to NAKS, for the defective Product or part.

NAKS is not responsible for the cost of removal of the defective Product or part, damages due to removal, or any expenses incurred in shipping the Product, or the installation of the repaired or replaced Product or part.

The warranties set forth above do not apply to any components, accessories, parts or attachments manufactured by other manufacturers; such being subject to the manufacturer's warranty, if any. To the extent not prohibited by the manufacturer's warranty, NAKS shall pass to you such manufacturer's warranty.

THIS WARRANTY IS IN LIEU OF ALL OTHER WARRANTIES, EXPRESS OR IMPLIED, ARISING BY LAW OR OTHERWISE, INCLUDING WITHOUT LIMITATION THE IMPLIED WARRANTIES OF MERCHANTABILITY AND FITNESS FOR A PARTICULAR PURPOSE, WHICH ARE HEREBY EXPRESSLY DISCLAIMED AND WAIVED. THIS WARRANTY CONSTITUTES NAKS SOLE AND EXCLUSIVE WARRANTY FOR DEFECTIVE GOODS AND PURCHASER'S SOLE AND EXCLUSIVE REMEDY FOR DEFECTIVE PRODUCTS.

No employee, agent, dealer, or other person is authorized to give any warranties on behalf of NAKS or to assume for it any other liability in connection with any of its products except in writing and signed by an officer of NAKS.

LIMITATION OF LIABILITY. NAKS' cumulative liability to you and any other persons for all claims in any way relating to or arising out of the Products, including, but not limited to, any cause of action sounding in contract, tort, or strict liability, shall not exceed the total amount of the purchase price paid for those Products which are the subject of any such claim. This limitation of liability is intended to apply without regard to whether other provisions of this agreement have been breached or have proven ineffective even if NAKS has been advised of the possibility of such claims or demands. In no event shall NAKS be liable to you or any other person for any loss of profits or any incidental, special, exemplary, or consequential damages for any claims or demands brought by you or such other persons. BECAUSE SOME JURISDICTIONS DO NOT ALLOW THE EXCLUSION OR LIMITATION OF LIABILITY FOR CONSEQUENTIAL OR INCIDENTAL DAMAGES, THIS LIMITATION MAY NOT APPLY TO YOU.

NAKS' maximum liability to you and to any end user is as set forth above. NAKS makes no warranty to anyone for any products not manufactured by it and shall have no liability for any use or installation of any products (whether manufactured by NAKS or other manufacturers) not specifically authorized by this sale. You acknowledge various warnings by NAKS regarding the Products and their installation and use. If NAKS incurs any claims, lawsuits, settlements, or expenses (including attorney fees) for any loss, injury, death or property damage including, but not limited to, claims arising out of your or any end user's installation or use of the Products, you agree to indemnify and hold NAKS harmless.

REPLACEMENT PARTS. If replacement parts are ordered, purchaser warrants that the original components in which these replacement parts will be placed are in satisfactory working condition, and when said replacement parts are installed, the resultant installation will operate in a safe manner, at speeds and temperatures for which the original product was purchased.

TECHNICAL ADVICE AND RECOMMENDATIONS, DISCLAIMER. Notwithstanding any past practice or dealings or any custom of the trade, sales shall not include the furnishing of technical advice or assistance or system design. Any such assistance shall be at NAKS' sole option and may be subject to additional charge(s).

NAKS assumes no obligation or liability on account of any recommendations, opinions or advice as to the choice, installation or use of Products. Any such recommendations, opinions or advice are given and shall be accepted at your and the end-user's risk and shall not constitute any warranty or guarantee of such Products or their performance.

2018 © North American Kitchen Solutions • 172 Reaser Court, Elyria, OH 44035

Toll Free: (800) 715-1014

customerservice@naksinc.com